

Yoke Grade 8 Insulated Blank Swivel with Ball Bearing BS EN 1677-1+2

The William Hackett Grade 8 forged lifting components are manufactured by YOKE from alloy steel in accordance with EN1677. All forged components are individually magnaflux crack detected after heat treatment, they are then individually proof load tested to 2.5 times working load limit in accordance with EN1677. Only components fully compliant with all aspects of EN1677 can be used in chain slings certified to EN818-4. The William Hackett Grade 8 lifting components are suitable for use in a temperature range of -40°C up to 200°C without reduction in working load limit.

Insulated Blank Swivels with ball bearing are individually tested to resist 1500 volts.

Designed for protection of overhead crane during welding operations on suspended loads.

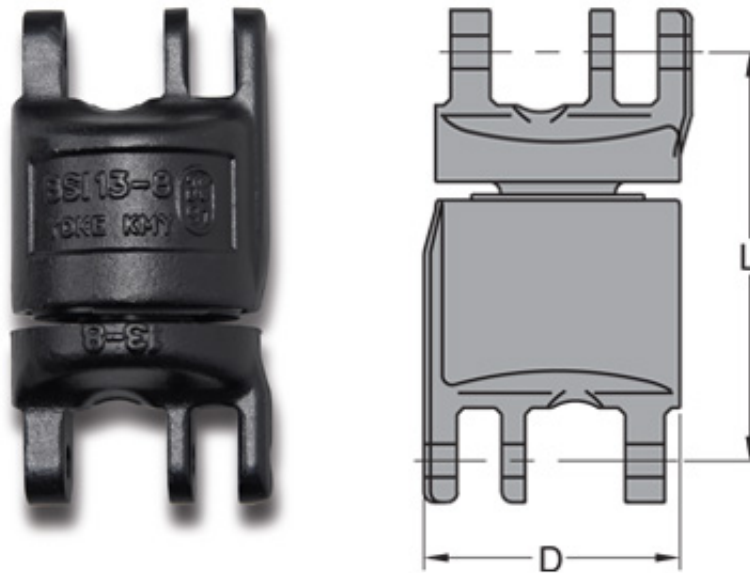

SPECIFICATIONS

Part Code	Chain Size mm	D mm	L mm	W.L.L. Tonnes	Box Quantity	Mass Kg
8-088-07	7,8	50	75	2.0	36	0.5
8-088-10	10	62	94	3.15	16	1.1
8-088-13	13	77	123	5.3	8	2.3
8-088-16	16	94	143	8.0	4	4.2
8-088-20	20	109	164	12.5	3	6.4