

Radiolink plus



Wall or Cab
Mount Bracket
available for handheld
Part No.
SU3282



Features and benefits:

- Proprietary 2.4 GHz wireless
- Industry leading wireless range of 700m/2300ft
- Error free data transmission
- Unrivalled resolution
- Environmentally sealed to IP67/NEMA6
- 90db Audible overload alarm
- Unmatched battery life of 1200hrs
- Internal antennae
- Compact size
- Remote on-off
- Lightweight aluminium
- 100 Hz Peak hold
- Advanced options available
- Push button tare
- Design validated by F.E.A.

Capable of both weighing and dynamic load monitoring, the latest Radiolink plus is constructed of high-quality aircraft grade aluminium and features an advanced internal design structure. This internal design structure not only provides the product with an unrivalled strength to weight ratio but it also allows the use of a separate internal sealed enclosure providing the load cell's electronic components with IP67/NEMA6 environmental protection even with the battery cover plate missing, making this industry leading dynamometer even more suitable for use in the harshest environments.

Featuring industry leading wireless technology and range of 700m/2300ft, the versatile Radiolink plus is supplied with an update rate of 3Hz and can be easily configured to run at industry leading speeds of up to 200Hz. Data is transmitted wirelessly utilising the latest in IEEE 802.15.4 (2.4 GHz) technology providing safe, high integrity, error free transmission of both static weight and dynamic load to a wireless handheld controller.

Designed for measurement of both static and dynamic loads the Radiolink plus can also be used in combination with

Straightpoint's range of SW-MWLC high speed wireless data logging software allowing for simultaneous control, display and real time data logging of up to 100 Straightpoint wireless load cells. The Radiolink plus may also be used with Straightpoint's Proof Test plus software package allowing the operator to perform load tests at a safe distance and generate real time test certificates on site.

The Radiolink plus utilises easily sourced AA alkaline batteries and features advanced circuitry designed to protect the unit from damage associated with incorrectly installed batteries. This advanced circuitry extends battery life and the use of easily sourced alkaline batteries eliminates issues associated with rechargeable battery pack charging, failure and replacement.

A full array of wireless accessories are also available including signal boosters, LED wireless scoreboards and base stations with analogue (4-20mA, 0-10v, 0-5v) or digital (RS232/485, Modbus RTU, and ASCII serial communications protocol) outputs.

It is easy to see why, globally, the Radiolink plus is the number one choice for weighing and dynamic load monitoring in critical lift planning and execution.



making the lifting industry a safer place

Also available with hazardous area approval



ATEX / IECEx
Ex ia II C T4 Ga

Certification numbers:

RLP ATEX

IECEx SIR 15.0071X / Sira 15ATEX2195X

SW-HHP ATEX

IECEx SIR 15.0072X / Sira 15ATEX2196X

Add 'ATEX' to the part number when ordering ATEX/IECEx products. For example: RLP5T-ATEX

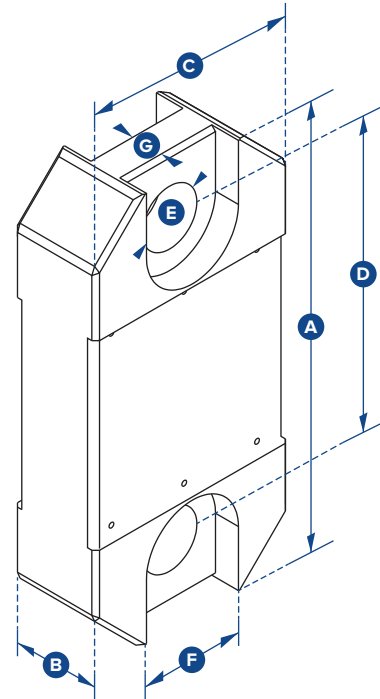

Part Number	RLP1T	RLP2T5	RLP5T	RLP12T	RLP25T	RLP35T	RLP50T	RLP75T	RLP100T	RLP150T	RLP200T	RLP250T	RLP300T
Capacity	1,000kg 2200lb	2.5te 5500lb	5te 11000lb	12te 26000lb	25te 55000lb	35te 77000lb	50te 110000lb	75te 165000lb	100te 220000lb	150te 330000lb	200te 440000lb	250te 550000lb	300te 660000lb
Resolution	0.5kg 1lb	0.001te 2lb	0.001te 2lb	0.002te 5lb	0.005te 10lb	0.005te 10lb	0.01te 20lb	0.01te 20lb	0.05te 100lb	0.05te 100lb	0.1te 200lb	0.1te 200lb	0.1te 200lb
Units	kg lb	te lb	te lb	te lb	te lb	te lb	te lb	te lb	te lb	te lb	te lb	te lb	te lb
Weight	1.4kg 3.1lb	1.4kg 3.1lb	2kg 4.4lb	3.2kg 7.1lb	5kg 11lb	8.6kg 19lb	11.5kg 25.3lb	16kg 35.3lb	34kg 75lb	46kg 101.4lb	72kg 158.7lb	72kg 158.7lb	118kg 260lb
Safety Factor	12:1	5:1	5:1	5:1	5:1	5:1	5:1	5:1	5:1	4:1	5:1	4:1	5:1
Battery Type	Handheld 2 x AA/Load cell 4 x AA												
Battery Life	Handheld 60 hours/Load cell 1200 hours continuous												
Display Type	6 digit 25mm / 1" LCD												
Operating Temp	-10°C to +50°C / 14°F to 122°F												
Accuracy	± 0.3% of applied load												
Frequency	2.4 GHz												
System Range	700 metres / 2300 feet												
Data Rate	3 Hz - up to 200 Hz can be ordered for dynamic load monitoring applications												
Protection	IP67 / NEMA 6												
Dimension A	204 8.03"	204 8.03"	249 9.80"	305 12.01"	340 13.39"	393 15.47"	424 16.69"	470 18.50"	608 23.94"	670 26.38"	700 27.56"	700 27.56"	806 31.73"
Dimension B	43 1.69"	43 1.69"	43 1.69"	47 1.85"	60 2.36"	75 2.95"	75 2.95"	75 2.95"	99 3.90"	99 3.90"	144 5.67"	144 5.67"	150 5.91"
Dimension C	101 3.98"	101 3.98"	101 3.98"	101 3.98"	115 4.53"	126 4.96"	163 6.42"	202 7.95"	255 10.04"	303 11.93"	320 12.60"	320 12.60"	426 16.77"
Dimension D	146 5.75"	146 5.75"	165 6.50"	193 7.60"	215 8.46"	225 8.86"	230 9.06"	260 10.24"	320 12.60"	360 14.17"	350 13.78"	350 13.78"	350 13.78"
Dimension ØE	24.5 0.96"	24.5 0.96"	38 1.50"	47.5 1.87"	55 2.17"	60 2.36"	76 2.99"	76 2.99"	109 4.29"	109 4.29"	132 5.20"	132 5.20"	160 6.30"
Dimension F	48 1.89"	48 1.89"	66 2.60"	Not relevant in this capacity									
Dimension G	19 0.75"	19 0.75"	32 1.26"										
Crosby Shackle	G2130						G2140						
Loading Pin Ø	19 3/4"	19 3/4"	25 1"	35 1 3/8"	51 2"	57 2 1/4"	57 2 1/4"	70 2 3/4"	83 3 1/4"	95 3 3/4"	121 4 3/4"	127 5"	152 6"