

Loadblock plus



Features and benefits:

- Large 25mm/1" LCD Display
- High resolution
- 100Hz Peak hold
- Compact size
- Push button tare
- Preset tare
- RS485 port for connection to datalogging system
- Selectable units te, lbs, kN & kg

The Loadblock plus is a low capacity, self-indicating compression load cell, used in many testing and load monitoring applications worldwide.

The integral display eliminates the need for a separate display or cable assembly that can be easily damaged. Applications include the measurement of loads associated with the testing of hydraulic presses, cylinders or jacks.

This latest version of Straightpoint's Loadblock has advanced features and benefits providing solutions for today's complicated load test and force monitoring needs. Features include full function push button controls for tare, units of measure (lbs, kg, kN, and tonnes), peak hold, pre-set tare, audible set-point alarm and an overload counter.

This crucial overload alarm counter is a requirement for many safety and quality control departments, as it keeps track of overload events, allowing the load cell in question to be removed from service immediately, following a calibration voiding overload event. The load cell in question can then be sent out for proper testing and, if necessary, recalibration before re-entering service.

The advanced microprocessor based electronics provide the Loadblock plus with high speed read rates (500/sec), extreme

resistance to industrial level noise and unprecedented stability.

This high stability provides the Loadblock plus with 5,000 + divisions and the highest standard resolution of any self-indicating compression load cell on the market today.

The unit also features a RS-485 serial output port allowing for remote viewing with either the Handheld plus digital display/controller or Windows PC desktop controller data logging software.



making the lifting industry a safer place

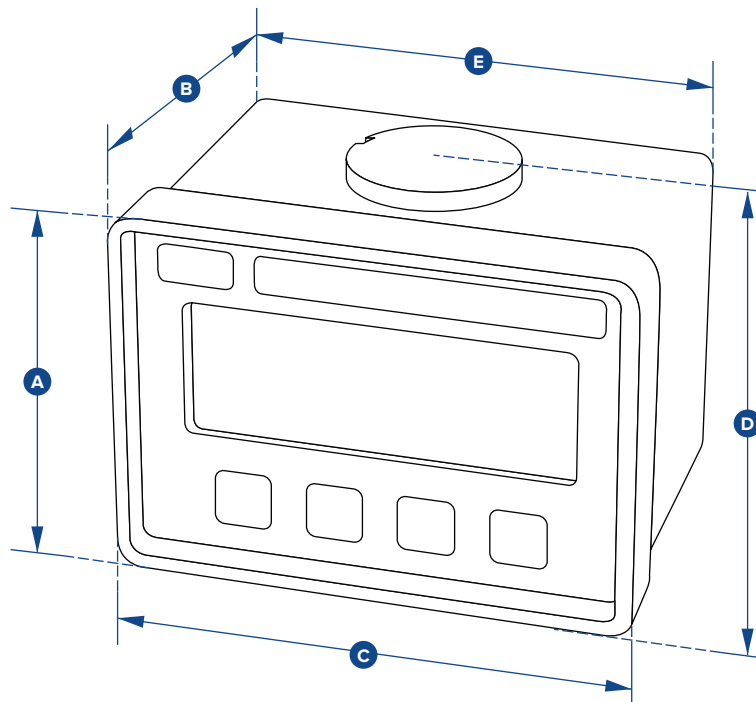

Part Number	LBP250KG	LBP500KG	LBP1T	LBP2T	LBP5T
Capacity	250kg	500kg	1te	2te	5te
	550lb	1100lb	2200lb	4400lb	11000lb
Resolution	0.1kg	0.2kg	0.0005te	0.001te	0.001te
	0.2lb	0.5lb	1lb	2lb	2lb
Units	t, kg, kN and lb				
	lb, te, kN and kg				
Weight	900g	900g	900g	1.5kg	3.1kg
	2lb	2lb	2lb	3.3lb	6.8lb
Safety Factor	4:1	5:1	5:1	5:1	5:1
Battery Type	9v PP3				
Battery Life	80hrs continuous				
Display Type	6 digit 25mm LCD / 6 digit 1" LCD				
Operating Temp	-10°C to 50°C / 14°F to 122°F				
Accuracy	±0.3% of applied load				
Protection	IP65 / NEMA 4X				
Dimension A	81	81	81	92	92
	3.19"	3.19"	3.19"	3.62"	3.62"
Dimension B	81	81	81	117	136
	3.19"	3.19"	3.19"	4.61"	5.35"
Dimension C	113	113	113	112	112
	4.45"	4.45"	4.45"	4.41"	4.41"
Dimension D	90	90	90	104	115
	3.54"	3.54"	3.54"	4.09"	4.53"
Dimension E	104	104	104	Not available in this capacity	
	4.09"	4.09"	4.09"		