

Compression Load Cell

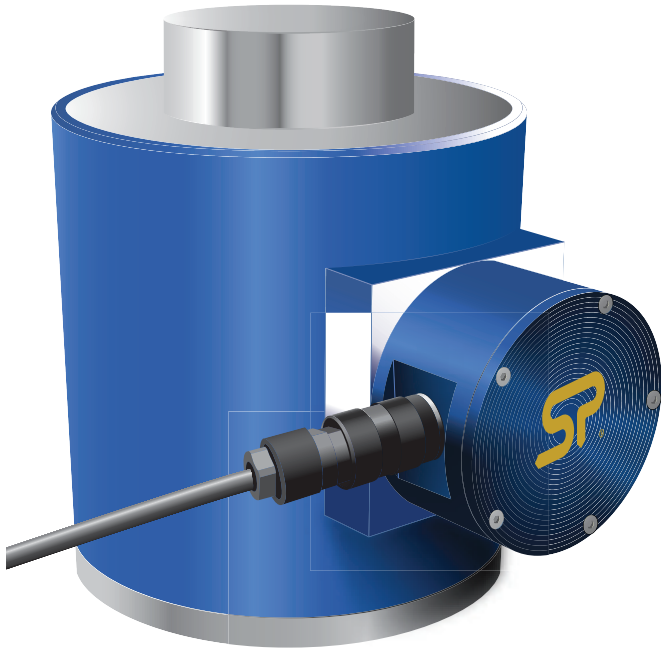

Features and benefits:

- Compact size
- Environmentally sealed to IP67/NEMA6
- Optional analogue outputs
- Stainless steel element
- High accuracy
- Lightweight
- Unrivalled resolution
- Custom versions available
- Design validated by F.E.A.



Requires connection to Straightpoint's Handheld plus (HHP), Desktop Controller data logging software (DCP10M) or External Amplifier range (SA-3420) that can be configured to provide outputs such as 4-20mA, 0-10v, 0-5v for PLC or data logger integration.

Manufactured in ranges from 5t to 500t - other capacities available on application.

Straightpoint compression load cells are manufactured to the same stringent standards as all Straightpoint products. The bodies are machined from high grade stainless steel, offering excellent strength and anti-corrosion properties. Compression load cells can be supplied with optional loadcaps to protect objects being tested.

The compact lightweight design provides ease of use and superior portability, allowing Straightpoint compression load cells to be used in a broad range of industries including mining, energy, defence, heavy rigging, shipping, and general transportation sectors.

Utilising the same advanced microprocessor based electronics as all Straightpoint products, Straightpoint's compression load cells benefit from high sampling rates, extreme resistance to industrial level noise and unprecedented stability. This high stability gives this product over 5,000 divisions and the highest standard resolution of any high capacity compression load cell on the market today.

Like all Straightpoint products, Straightpoint compression load cells offer robust construction, advanced electronics, industry leading resolution and accuracy all at a cost-effective, affordable price.



making the lifting industry a safer place

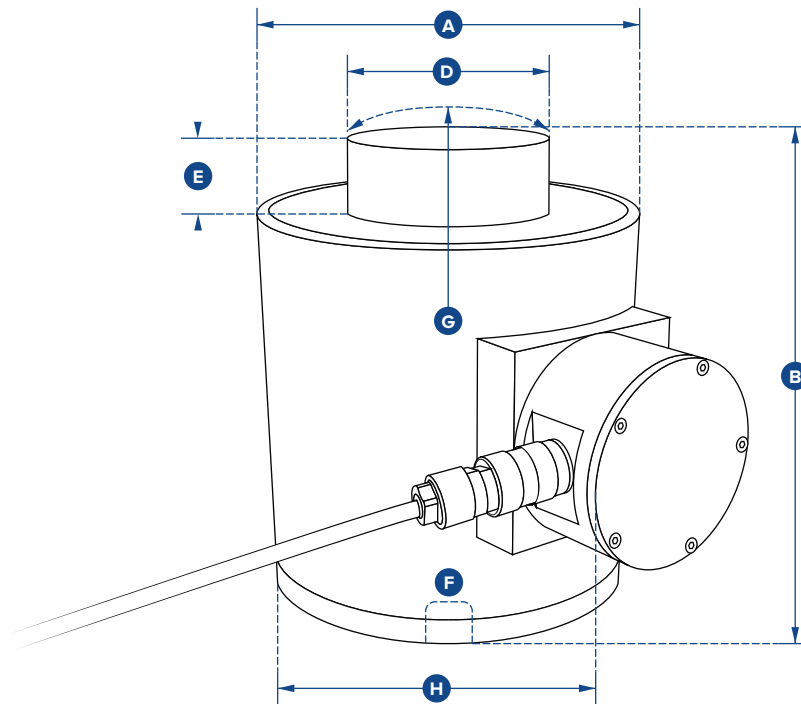

Part Number	NI5TC	NI10TC	NI25TC	NI50TC	NI100TC	NI150TC	NI300TC	NI500TC
Capacity	5te	10te	25te	50te	100te	150te	300te	500te
	11000lb	22000lb	55000lb	110000lb	220000lb	330000lb	660000lb	1100000lb
Resolution	0.001te	0.002te	0.005te	0.01te	0.05te	0.05te	0.1te	0.2te
	2lb	5lb	10lb	20lb	100lb	100lb	200lb	500lb
Units	tonne							
	lb							
Weight	3.2kg	3.2kg	3.2kg	6.2kg	15.5kg	15.5kg	65kg	65kg
	7lb	7lb	7lb	13.64lb	34lb	34lb	143lb	143lb
Safety Factor	3:1							
Operating Temp	-10°C to +50°C / 14°F to 122°F							
Accuracy	±0.3% of applied load							
Protection	IP67 / NEMA 6							
Dimension ØA	76	76	76	102	152	152	185	185
	2.99"	2.99"	2.99"	4.02"	5.98"	5.98"	7.28"	7.28"
Dimension B	83	83	83	127	184	184	300	300
	3.27"	3.27"	3.27"	5.00"	7.24"	7.24"	11.81"	11.81"
Dimension ØD	32	32	32	59	80	80	155	155
	1.26"	1.26"	1.26"	2.32"	3.15"	3.15"	6.10"	6.10"
Dimension E	10	10	10	13	26	26	27.5	27.5
	0.39"	0.39"	0.39"	0.51"	1.02"	1.02"	1.08"	1.08"
Dimension F	M12 x 1.75	M12 x 1.75	M12 x 1.75	M20 x 2.5	M20 x 2.5	M20 x 2.5	M20 x 2.5	M20 x 2.5
	M12 x 1.75	M12 x 1.75	M12 x 1.75	M20 x 2.5	M20 x 2.5	M20 x 2.5	M20 x 2.5	M20 x 2.5
Dimension G	152	152	152	152	432	432	432	432
	5.98"	5.98"	5.98"	5.98"	17.01"	17.01"	17.01"	17.01"
Dimension H	96	96	96	154	204	204	237	237
	3.78"	3.78"	3.78"	6.06"	8.03"	8.03"	9.33"	9.33"