

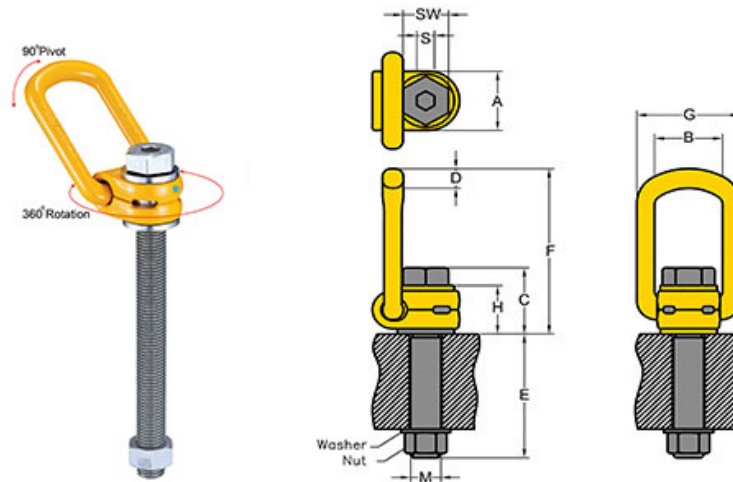







Yoke Digital Lifting Point Long Bolt - type 211 metric thread

- Rotates through 360° and pivots 90°.
- Manufactured from alloy steel, quenched and tempered.
- Manufactured and tested in accordance with EN1677-1.
- Load rated parts are 100% magnaflux crack detected.
- Individual forged parts and cap screw are traceable to Test Certification.
- Bolts are Metric thread (ASME / ANSI B18.3.1M).
- Proof tested to 2.5 times the WLL.
- Fatigue rated to 1.5 times the WLL.
- Design Factor 4 : 1
- All YOKE Lifting points meet or exceed all the requirements of ASME B30.26.
- Quick and simple assembly, just a tapped hole is required.



Part Code	WLL tonnes	Thread M mm	A mm	B mm	C mm	D mm	E mm	F mm	G mm	H mm	S mm	SW mm	Torque in Nm	Mass kg
8-211-003/105L	0.30	M8 x 1.25	30	35	35	10	76	86	55	29	6	13	30	0.4
8-211-006/125L	0.63	M10 x 1.50	30	35	36	10	96	86	55	29	6	17	60	0.4
8-211-010/150L	1.00	M12 x 1.75	33	38	44	14	114	99	57	36	8	19	100	0.5
8-211-015/185L	1.50	M16 x 2.00	33	38	46	14	149	99	57	36	10	24	150	0.7
8-211-025/230L	2.50	M20 x 2.50	50	54	56	17	187	142	82	43	12	30	250	1.7
8-211-040/265L	4.00	M24 x 3.00	50	54	59	17	221	143	82	44	14	36	400	2.0
8-211-050/340L	5.00	M30 x 3.50	60	65	81	23	279	170	99	62	17	46	500	2.9
8-211-080/300L	8.00	M36 x 4.00	77	85	101	27	222	225	124	78	22	55	800	6.9
8-211-100/350L	10.00	M42 x 4.50	77	85	104	27	272	225	124	78	24	65	1000	7.9
8-211-150/350L	15.00	M42 x 4.50	95	104	112	36	264	258	158	86	24	65	1500	13.5
8-211-200/385L	20.00	M48 x 5.00	95	104	120	36	295	260	158	90	27	75	2000	15.5

LIFTING POINT LONG BOLT WORKING LOAD APPLICATION FACTORS

											
Number of legs		1	2	1	2	2		2	3-4		3-4
Load Direction		0°	0°	90°	90°	0-45°	45-60°	unsymm.	0-45°	45-60°	unsymm.
Part Code	Thread	WLL Tonnes									
8-211-003/105L	M8	0.30	0.60	0.30	0.60	0.42	0.30	0.30	0.63	0.45	0.30
8-211-006/125L	M10	0.63	1.26	0.63	1.26	0.88	0.63	0.63	1.32	0.95	0.63
8-211-010/150L	M12	1.00	2.00	1.00	2.00	1.40	1.00	1.00	2.10	1.50	1.00
8-211-015/185L	M16	1.50	3.00	1.50	3.00	2.10	1.50	1.50	3.10	2.20	1.50
8-211-025/230L	M20	2.50	5.00	2.50	5.00	3.50	2.50	2.50	5.20	3.70	2.50
8-211-040/265L	M24	4.00	8.00	4.00	8.00	5.60	4.00	4.00	8.40	6.00	4.00
8-211-050/340L	M30	5.00	10.00	5.00	10.00	7.00	5.00	5.00	10.50	7.50	5.00
8-211-080/300L	M36	8.00	16.00	8.00	16.00	11.20	8.00	8.00	16.80	12.00	8.00
8-211-100/350L	M42	10.00	20.00	10.00	20.00	14.00	10.00	10.00	21.00	15.00	10.00
8-211-150/350L	M42	15.00	30.00	15.00	30.00	21.00	15.00	15.00	31.50	22.50	15.00
8-211-200/385L	M48	20.00	40.00	20.00	40.00	28.00	20.00	20.00	42.00	30.00	20.00